



PA-1000 BT

ANR AVIATION HEADSET

ANR Instruction: The Active Noise Reduction CN-1000AC-BT Headset is a headset that can isolate, offset and cancel noise. In comparison with passive headsets, it can, under noisy circumstances, provide a quieter and more comfortable sensation, by reducing background noise. Therefore, make it possible to improve the audio quality and articulation, resulting in a higher operation safety factor. The noise cancelling circuitry reduces outside noise considerably more than a standard headset, making it more comfortable for the pilot in the aircraft.

OPERATION

The battery module requires two AA battery. The power of CN-1000AC-BT comes from AA battery, not aircraft power.

1. Insert or change Batteries: ①press from the base of the triangle on the cover, see Figure 1; ②push the cover out of the safety lock, see Figure 2; ③up tilt the end of the cover and remove the whole cover; put the batteries in; ④put the cover latch into the notch and push it back, see Figure 3.
2. S/M switch: There is an s/m switch inside the battery box, see Figure 4. When the switch is on "M", the output of earphone plug is mono and "S" means stereo.
3. Press power button for 0.5 second, ANR starts working.

Light Indication for Power:

Flash in green—battery fully charged;
Flash every 2 seconds in amber—battery low;
Flash every 1 second in red—battery dying.

4. When it is on, press bluetooth button for 1 second to start the Bluetooth function.

Mode Setting:

A: Intercom Priority —When intercom is busy, Bluetooth and AUX will be attenuated.
B: Intercom, Bluetooth and AUX —All three channels are open.
C: Intercom Only —Only intercom is on. Bluetooth and AUX are both off.

The prioritization of Bluetooth and AUX is:
Bluetooth phone > AUX > Bluetooth music

5. Bluetooth works when the mode setting switch is positioned on A or B.

Bluetooth volume control: Press "+" or "-" to turn up or down the volume of bluetooth connected device. Holding "+" or "-" will keep the volume up or down, see Figure 5

Pairing: device name—BT-ANR; pairing code: 0000 (four zeros). The first bluetooth device connecting to the headset will be paired automatically.

From the second one, manual pairing is required. Press the bluetooth button for 5 seconds to start pairing.

Re-pairing: re-pairing starts automatically if the phone moves out of the Bluetooth scope and thus gets disconnected.

The phone will be disconnected if the re-pairing cannot succeed in 5 minutes.

Re-connecting: click the Bluetooth button to re-connect to the last connected phone.

Clearing the pairing record: press both Bluetooth volume control buttons on the side for 3 seconds.

Making calls: dialing the numbers on your phone.

Click the Bluetooth button twice to return the last incoming call.

Receiving calls: Press the Bluetooth button and answer the call after BEEP.

End a call: Press the Bluetooth button. The call ends after BEEP.

Rejecting calls: Press the Bluetooth button for 3 seconds.

Light Indication for Bluetooth:

Flash in blue and red—pairing.
Flash in red twice—disconnected.
Flash in blue regularly—phone connected.
Short flash in blue—line busy.

6. Press power button for 2 seconds to turn ANR off.

Notice:

1. Pls use non-rechargeable alkaline AA batteries.
2. To save on batteries, pls shut the power off when ANR is not in use.
3. Pls take out the batteries if ANR is left unused for a long period.

Prepare the headset for Use

1. Rotate the flexible boom overhead to wear the microphone on either the right or left side of the head.
2. Rotate the headset volume control (on the side of the battery box) down to the minimum position, before the headset plug is inserted into the aircraft or intercom.
3. With the headband resting securely on the top of the head, check that the ear seals are centered over the ears.
4. For best noise cancellation, position the microphone in front of your lips.
5. Insert the microphone plug (PJ068) into the aircraft or intercom microphone jack. Insert the earphone plug (PJ055) into the aircraft or intercom earphone jack.
6. Volume Adjustment Procedure: Rotate the volume control up to a comfortable level.
7. Auxiliary (AUX) audio input: Insert the plug (3.5mm plug) of your external audio device into the AUX jack on the side of battery box as indicated. The volume is controlled by your audio device.
8. Bluetooth function: as indicated in operation 5.

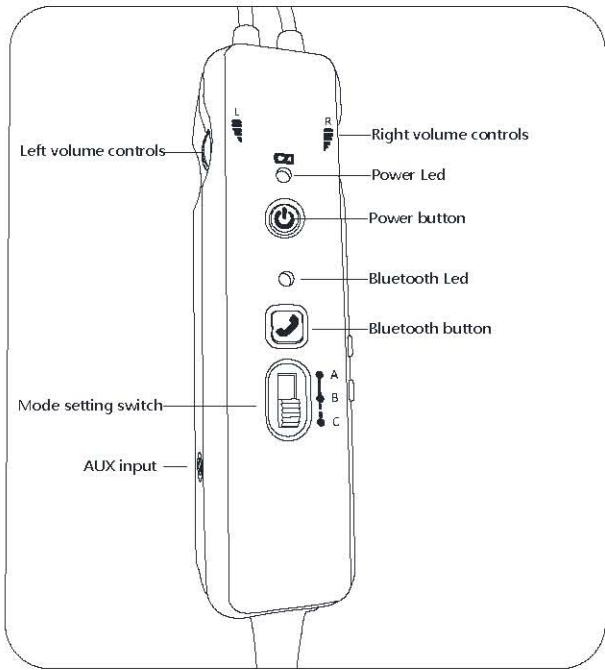

Control module layout

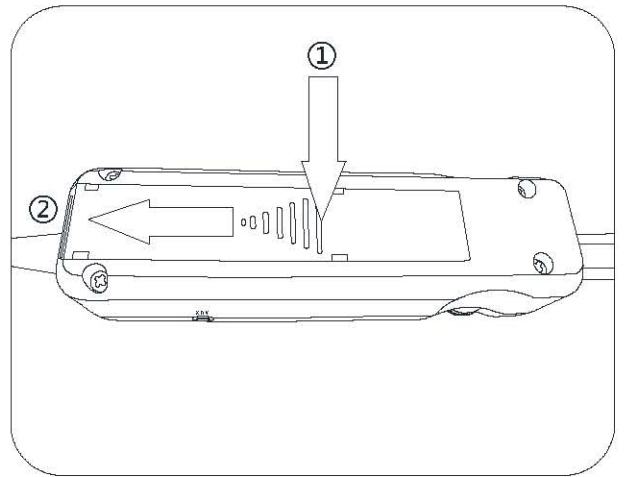

Figure 1

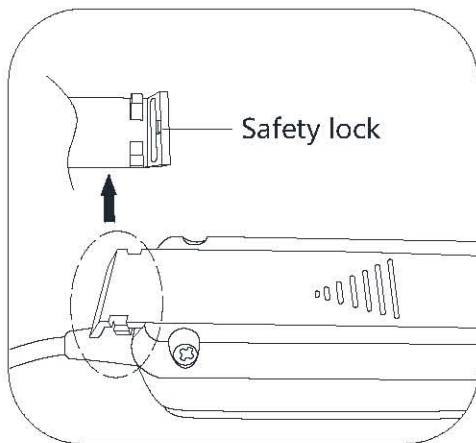

Figure 2

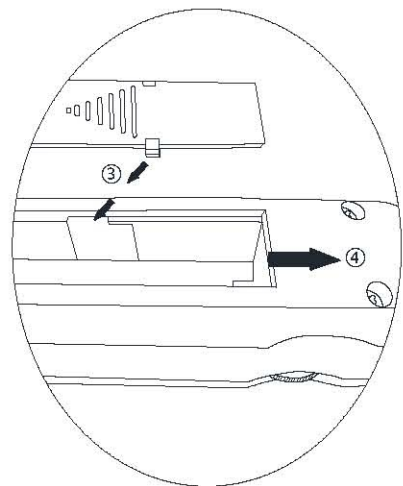

Figure 3

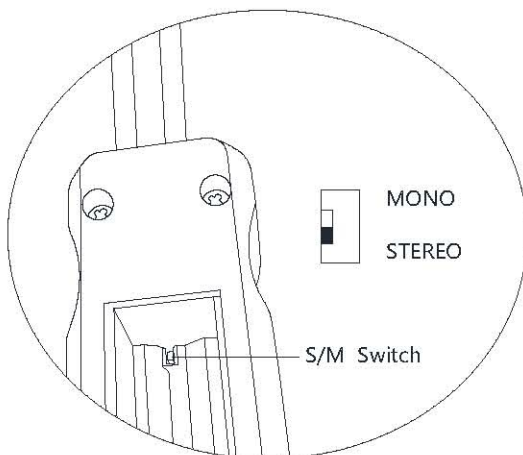

Figure 4

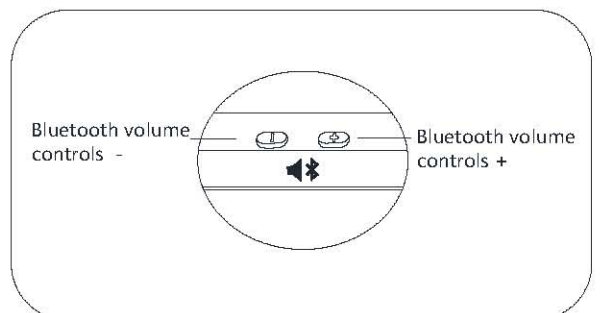

Figure 5

Specifications

PNR Noise Reduction Ratings (NRR) : 23dB

ANR Noise Reduction Ratings (NRR) : 29dB

Headphone

Type: Dynamic ($\Phi 30$)

Frequency Response: 50 Hz to 20 kHz

Sensitivity: 95 \pm 5 dB SPL

(1 kHz, 1 mW input per earcup side)

full volume on ear simulator

Active Noise Attenuation:

Dynamic 42 ohms:

Rate Input: 30mW Max. Input: 100mW

Speech Sound:

Dynamic 300 ohms:

Rate Input: 30mW Max. Input: 100mW

Microphone and Amplifier:

Element Type: Noise-canceling electret

Frequency Response: 100Hz to 5 kHz

Operating Voltage (supplied by aircraft): 8-32 Volts DC

Matching Impedance: 150-1000 ohms

Sensitivity: -33 \pm 4 dB (Ref: 0dB SPL=20.0uPa at 1 kHz
with 10 Vdc 150 ohms AC load)

General:

Temperature: Operating: - 20 to 70°C

Cordage: Straight cord from headset to molded plug, 150CM

Intercom Connections:

Earphone Plug : PJ-055 (.25" 6.3 Φ phone plug)

Microphone Plug : PJ-068 (.206" 5.2 Φ phone plug)

Weights: 290g

ANR Noise Reduction Specifications:

Attenuation Frequency Band20Hz~20 KHz

Main Attenuation Frequency Band20Hz~600Hz

Attenuation Capability.....29dB

Power Consumption30 mW

Headset size range Height: 10 to 14 cm

Color: Black **Boom:** Flexible Boom

HEADSET SCHEMATIC DIAGRAM

CN-1000AC-BT2

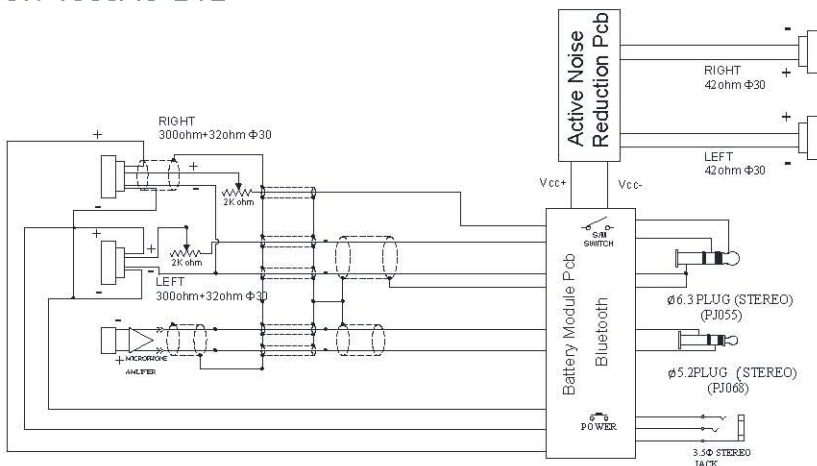

EXPLODED VIEW AND DISASSEMBLY INSTRUCTIONS

PARTS LIST
MODEL: PA-1000 BT

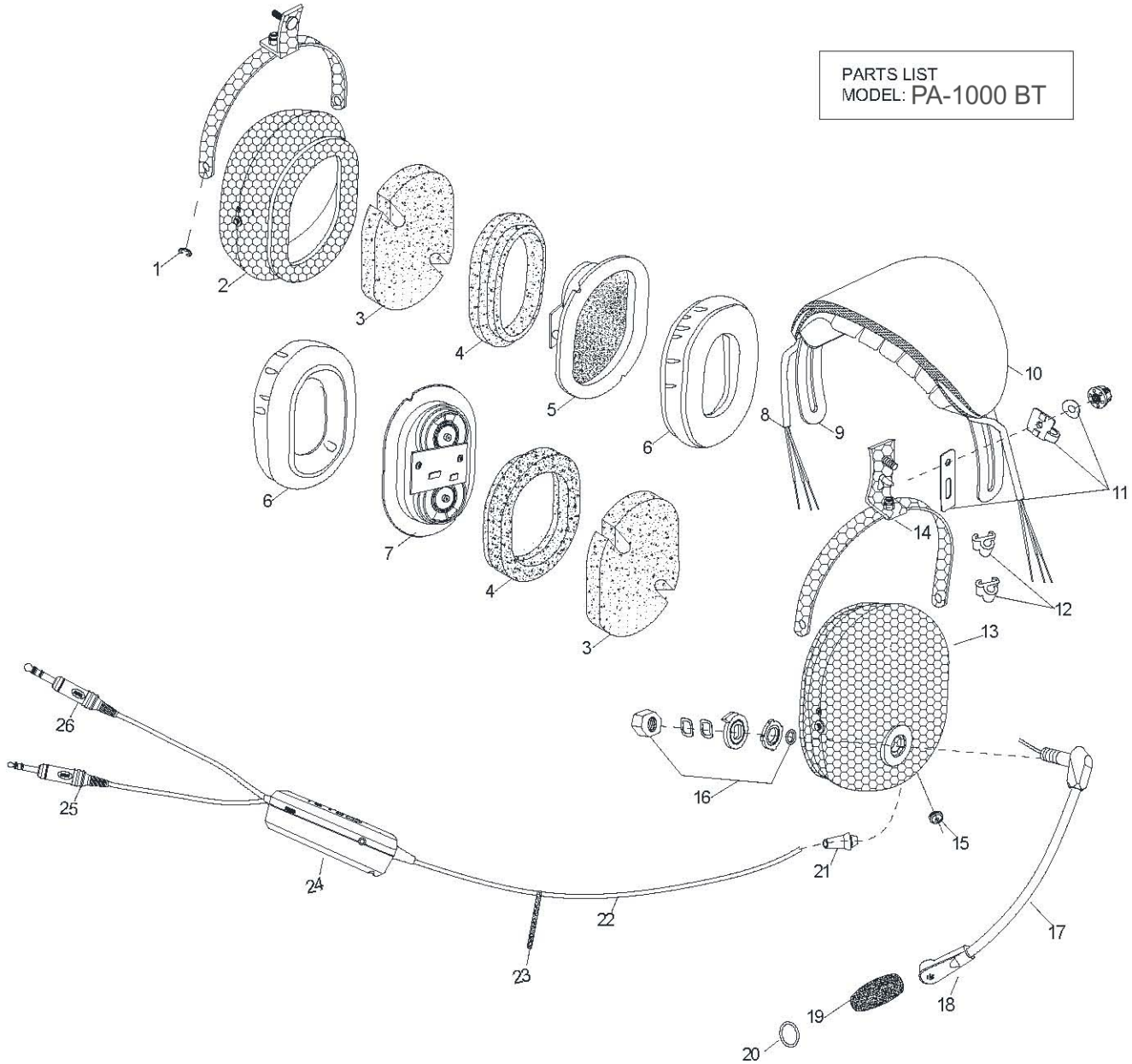

PARTS LIST

ITEM	P/N	DESCRIPTION	ITEM	P/N	DESCRIPTION
1	10ME0069	RETAINING RING	17	10KI0036	FLEXIBLE BOOM ASSEMBLY
2	10PL0038	RIGHT CARBON EARCUP	18	10EL0045	ELECTRET MICROPHONE
3	10SP0055	ABSORBENT NOISE FILTER (1)	19	10SP0054	MICROPHONE WINDSCREEN
4	10SP0056	ABSORBENT NOISE FILTER (2)	20	10PL0008	O RING
5	10EL0046	NOISE CANCELING PCB (RIGHT)	21	10PL0005	STRAIN RELIEF
6	10SP0049	PROTEIN LEATHER EARSEAL	22	10CR0004	COMM CORD , STRAIGHT
7	10EL0047	NOISE CANCELING PCB (LFET)	23	10SP0021	SELF-GRIPPING FASTENER
8	10CR0020	OVERHEAD CORD	24	10KI0038	BT BATTERY MODULE
9	10ME0068	HEADBAND , STAINLESS STEEL	25	10CR0005	Φ5.2 MOLDED PLUG CORD (PJ068)
10	10SP0005	HEADBAND CUSHION	26	10CR0015	Φ6.3 MOLDED PLUG CORD (PJ055)
11	10KI0020	CLAMP KIT	27		
12	10PL0002	OVERHEAD CORD CLAMP	28		
13	10PL0041	LEFT CARBON EARCUP	29		
14	10ME0010	STIRRUP	30		
15	10PL0004	GROMMET , RUBBER	31		
16	10KI0037	MIC BOOM ATTACHMENT KIT	32		

User's notes:

User's notes:

Salesman:

A large, empty rectangular box with a black border, intended for a signature or name.