



# PH - 101 AVIATION HEADSET

# HEADSET OPERATION

1. Rotate the spring tension boom overhead to wear the microphone on either the right or left side of the head.
2. Rotate the headset volume control (on the side of the headset opposite the microphone boom) fully counter-clockwise to the minimum position. before the headset plug is inserted into the aircraft or intercom
3. With the headband resting securely on the top of the head, check that the earseal are centered over the ears.
4. For best noise cancellation, position the microphone 0-6 mm from your lips .
5. Insert the microphone plug (PJ068) into the aircraft or intercom microphone jack. Insert the earphone plug ( PJ055 ) into the aircraft or intercom earphone jack.
6. Volume Adjustment Procedure  
Rotate the headset volume knob clockwise to a comfortable level.

## **Cautions:**

### 1: Proper Fit

Proper fit is critical to its noise attenuation effectiveness.

A: Push the headband down until it rests comfortably on the top of your head. Move the earcups slightly up or down or from side to side until you feel Maximum attenuation.

B: The use of eyeglasses will reduce the attenuation. Use thin temples on your glasses to keep noise leakage at a minimum.

### 2: Use in Impulsive Noise Area

NRR is based on continuous noise, may not be an accurate indicator of the impulsive noise such as gunfire.

For maximum protection, you can use ear plugs in addition to it.

### 3: Maintenance and Cleaning

In order for your headset working properly, always comply the following:

A: Never alter your headset.

B: If you see a defect such as splits in cups, seek immediate replacement.

### 4: Cleaning Instructions

A: Do not immerse in water.

B: Clean regularly with mild soap water. Sponge off headpad and earseals, Taking care to rinse thoroughly.

## HEADSET NOISE ATTENUATION DATA

The noise reduction or attenuation characteristics of communication headsets must be measured according to an accepted standard procedure if the characteristics of different headset are to be compared in a meaningful way.

The Noise Reduction Rating (NRR) is provided in accordance with U.S.EPA Regulation 40 CFR Part 211.Subpart B. The Range of Noise Reduction Rating for Existing Hearing Protectors is Approximately 0 to 30. (Higher Numbers Denote Greater Effectiveness)

Frequency[Hz]	125	250	500	1000	2000	3000	4000	6000	8000
Attenuation[dB]	14.3	21.5	27.1	31.8	36	39.5	41.3	39.7	37.0
Standard Deviation	3.3	2.4	1.5	1.6	1.3	2.1	2.1	2.0	1.3

# Specifications

**Noise Reduction Ratings ( NRR ): 24dB**

## **Headphone**

Type: Dynamic (  $\Phi$ 50 )

Frequency Response: 100Hz to 8 kHz

Sensitivity:  $95 \pm 5$  dB SPL (1 kHz, 1 mW input per earcup side)  
full volume on ear simulator

Impedance: 150 ohms (300 ohms each; wired in parallel)

Rate Input: 100mW

Max. Input: 250mW

## **Microphone and Amplifier:**

Element Type: Noise-canceling electret

Frequency Response: 150Hz to 5kHz

Operating Voltage (supplied by aircraft ): 8-32 Volts DC

Matching Impedance: 150-1000 ohms

Sensitivity:  $-33 \pm 4$  dB

(ref: 0dB SPL=20.0uPa at 1 kHz with 10 Vdc 150 ohms AC load)

## **General:**

**Temperature:** Operating: - 20 to 70°C

## **Cordage:**

PH-101 Straight cord from headset to molded plug, 150CM

## **Intercom Connections:**

Earphone Plug : PJ-055 ( .25" 6.3 $\Phi$  phone plug)

Microphone Plug : PJ-068 ( .206" 5.2 $\Phi$  phone plug)

## **Weights:**

PH-101 ----- 520g

## **Headset size range**

Height: 10 to 14 cm

## **Color:**

Green/Black

## **Boom:**

Flexible Boom

# EXPLODED VIEW AND DISASSEMBLY INSTRUCTIONS

PARTS LIST  
MODEL PH-101

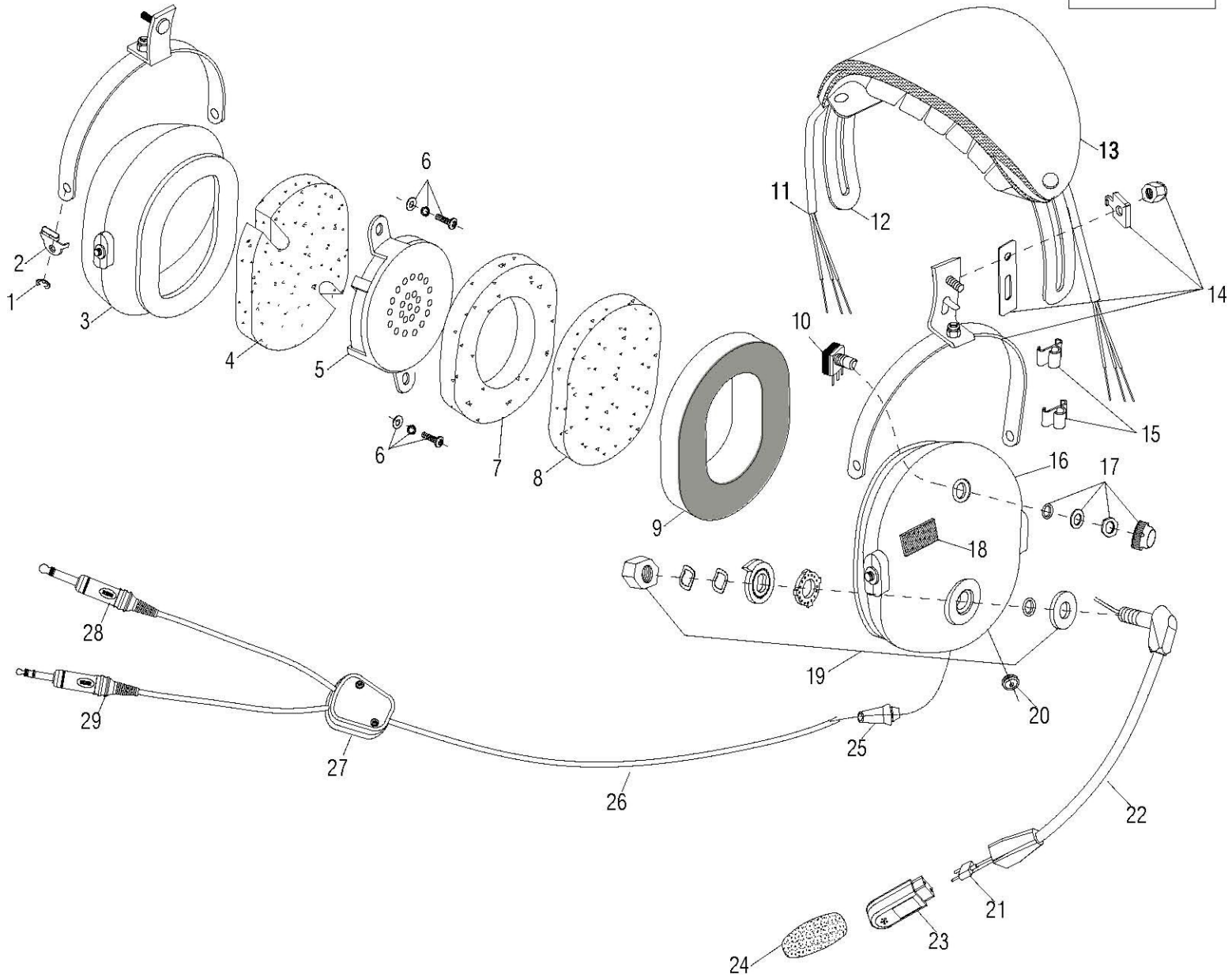

# PARTS LIST

ITEM	P/N	DESCRIPTION	ITEM	P/N	DESCRIPTION
<b>1</b>	10ME0001	RETAINING RING	<b>17</b>	10KI0002	VOLUME KNOB KIT
<b>2</b>	10ME0002	DOMESTOP , STAINLESS STEEL	<b>18</b>	10EL0003	JUNCTION BOARD , PCB
<b>3</b>	10PL0001	RIGHT EARCUP	<b>19</b>	10KI0005	MIC BOOM ATTACHMENT KIT
<b>4</b>	10SP0001	FILTER (3)	<b>20</b>	10PL0004	GROMMET , RUBBER
<b>5</b>	10EL0001	EARPHONE ASSEMBLY Φ50 300 OHMS□	<b>21</b>	10CR0007	MICROPHONE PLUG CORD
<b>6</b>	10ME0003	SCREW KIT	<b>22</b>	10KI0006	FLEXIBLE BOOM ASSEMBLY
<b>7</b>	10SP0002	FILTER (2)	<b>23</b>	10EL0005	ELECTRET MICROPHONE
<b>8</b>	10SP0003	FILTER (1)	<b>24</b>	10SP0006	MICROPHONE WINDSCREEN
<b>9</b>	10SP0004	EARSEAL ,PU	<b>25</b>	10PL0005	STRAIN RELIEF
<b>10</b>	10EL0002	VOLUME CONTROL 1K□	<b>26</b>	10CR0004	COMM CORD , STRAIGHT
<b>11</b>	10CR0001	OVERHEAD CORD	<b>27</b>	10PL0006	CORD JUNCTION BOX
<b>12</b>	10ME0004	HEADBAND , STAINLESS STEEL	<b>28</b>	10CR0006	Φ6.3 MOLDED PLUG CORD
<b>13</b>	10SP0005	HEADBAND CUSHION	<b>29</b>	10CR0005	Φ5.2 MOLDED PLUG CORD
<b>14</b>	10KI0001	STIRRUP & CLAMP KIT	<b>30</b>		
<b>15</b>	10PL0002	OVERHEAD CORD CLAMP	<b>31</b>		
<b>16</b>	10PL0007	LEFT EARCUP	<b>32</b>		

# HEADSET SCHEMATIC DIAGRAM

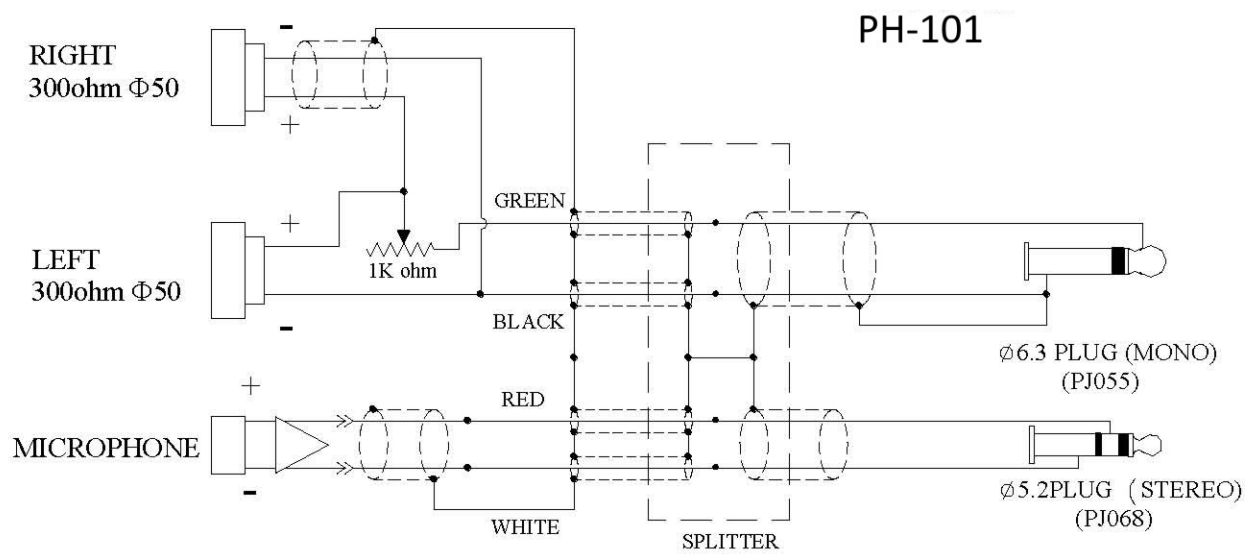

User's notes:

Salesman:

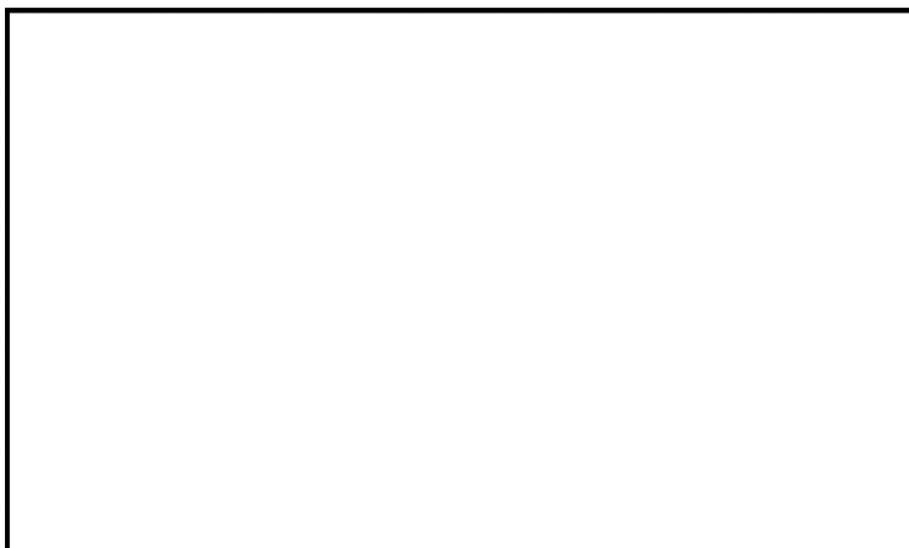
A large, empty rectangular box with a black border, intended for a signature or stamp.